

Product Description

Pillow Block Web Tension Bearing BZL

Special Features

- Pillow block with integrated web tension measuring function
- Low effort for construction, modification and assembly
- Measuring direction is individually selectable
- Interchangeable with common types of pillow blocks
- Bore holes and dimensions compatible to INA/FAG, NTN/SNR

Scope of Supply

- Force sensor with 5 meters fixed cable
- Bearing

Versions

- **Option S:** Right angle plug
- **Option F:** Use in potentially explosive atmospheres (Adaption Modul J-Box contained in the scope of supply)

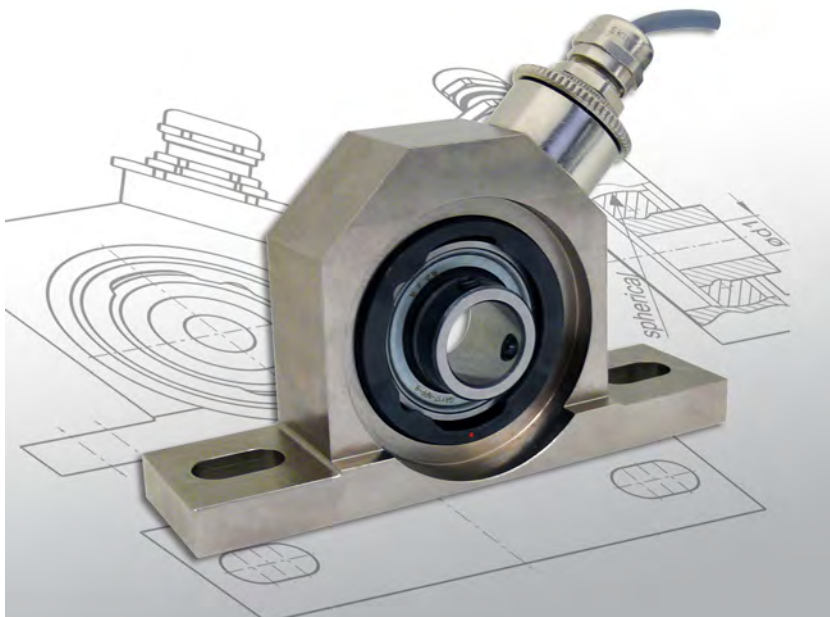

Option S:

- Right angle plug
- rotatable in all positions (IP67)

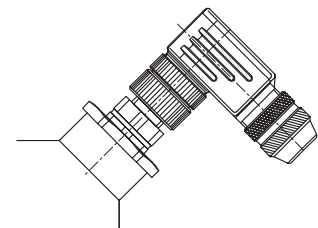

Application

The force sensors of the **BZL** series are suitable for the direct measurement of web tension forces.

The sensors are used like a pillow block web tension bearing for the measurement of tension forces in horizontal or vertical direction.

Due to the exchangeability with common types of pillow blocks they are easy to install without machine design modifications.

The **pillow block web tension bearing of the series BZL** consist primarily of a pillow block with a measuring inner part with an integrated bearing. The inner part component contains a double beam technology system with the well-known advantages of a good linearity and a high stiffness. The strain gauges wired as full bridge deliver a signal proportional to the force.

HAEHNE offers for all its sensors a corresponding range of amplifiers to condition the measuring signal and deliver the bridge voltage supply.

Technical Data	Values (%) based on nominal force	
Nominal force (measuring range)	100, 200, 500 N	1000 N
Max. operating force	160 %	130 %
Absolute max. force	1000 %	
Nominal rating (with Option F: J-Box necessary)	1,5 mV / V	
Combined error	0,5%	
Nominal ambient temperature	+ 10... +60° C	
Operational temperature range	- 10... +70° C	
Nominal resistance of strain gauge bridge	700 Ω	
Max. bridge supply voltage	10 VDC	
Protection class	IP52	
Sensor cable (standard)	PVC, grey, 4 x 0,34 mm ²	
Sensor cable (option F)	PVC, blue, 2 x 2 x 0,34 mm ²	

Installation Notice

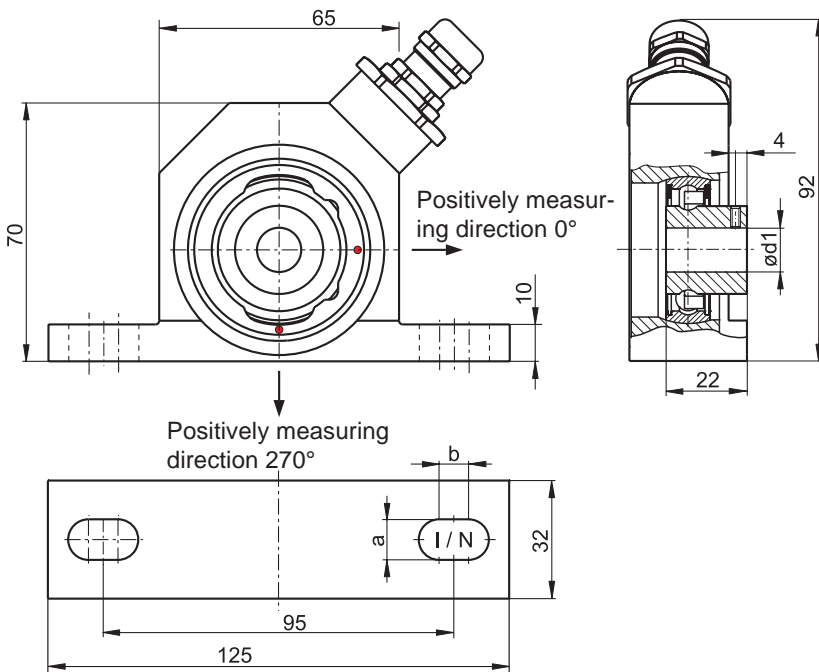
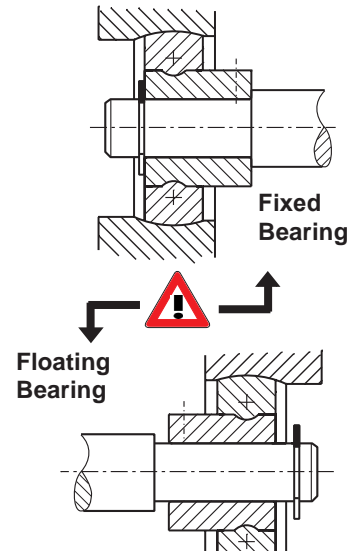

Ordering Example

BZL1-15R90-N200-S

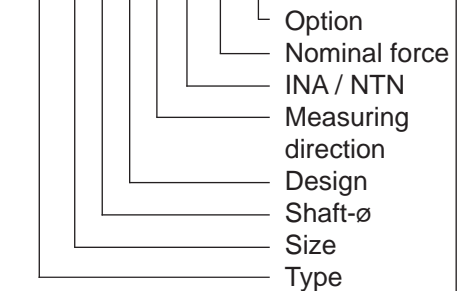

Size	d1	a x b	Nominal Force [N]	Bearing
1	12	I (11x8 for INA/FAG)	100	GAY12-NPP-B
	15		200	GAY15-NPP-B
	17	N (13x6 for NTN/SNR)	500	GAY17-NPP-B
			1000	

Design and measuring direction:

Within the use of two BZL at a measuring roll the sensors are supplied in pairs, so that the sensor plugs point into the same direction. With the order please indicate the execution " L " (Left) and " R " (Right).

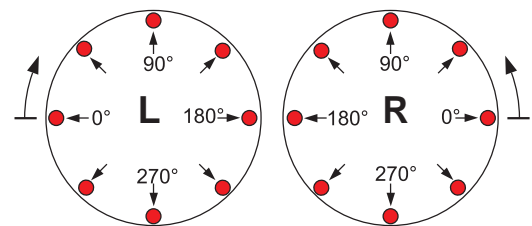
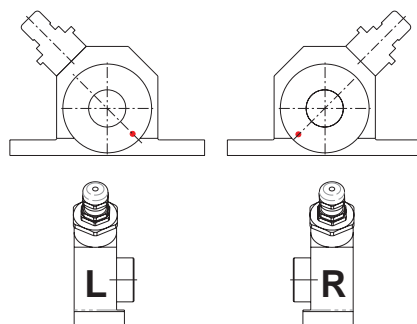

For the measuring direction indicate the desired angle. As standard steps of 45° are offered. Other measuring directions on request.