

# POSITAL

## FRABA

### ABSOLUTE ROTARY ENCODER MODBUS/TCP



#### Main Features

- Compact and Heavy-Duty Industrial Model
- Communication via Standard Protocols
- Integrated Web Server
- Interface: Modbus/TCP
- Housing: 58 mm  $\varnothing$
- Full shaft: 6 or 10 mm  $\varnothing$  /  
Hub Shaft 15 mm  $\varnothing$
- Resolution: max. 30 Bit = 1,073,741,824  
Steps Over 16384 Revolutions
- Code: Binary
- UL Listed

#### Mechanical Structure

- Aluminum Flange and Housing
- Stainless Steel Shaft
- Sealed Precision Ball Bearings
- Unbreakable and Durable Polycarbonate Code  
Disc
- Robust Electrical Connection with M12-Connector

#### Programmable Parameters

- Used Scope of Physical Resolution
- Total Scaled Resolution
- Preset Value
- Direction of Rotation (Complement)
- Different Modes for Output of Position, Velocity  
and time Stamp
- Network- and E-mail- Parameters

#### Electrical Features

- Status Indication with LEDs
- Temperature Insensitive  
IR-Opto-Receiver-ASIC
- Polarity Inversion Protection
- Over-Voltage-Peak Protection

FRABA Inc.

1800 East State Street, Suite 148, Hamilton, NJ 08609, USA

Tel. +1 609 750 8705, Fax. +1 609 750 8703

[www.posital.com](http://www.posital.com), [info@posital.com](mailto:info@posital.com)

### ABSOLUTE ROTARY ENCODER MODBUS/TCP

#### Technical Data

##### Electrical Data

Supply Voltage	10 - 30 V DC (Absolute Limits)*
Power Consumption	max. 4 Watt
EMC	Emitted Interference: EN 61000-6-4
	Noise Immunity: EN 61000-6-2
Bus Connection	Modbus/TCP
Transmission Rate	10/100 MBit
Accuracy of Division	$\pm 1/2$ LSB (up to 12 Bit), $\pm 2$ LSB (up to 16 Bit)
Step Frequency LSB	max. 800kHz (Valid Code)
Cycle Time	> 1 ms (Cyclic Mode), > 5 ms (Change of State) for TCP/IP > 5 ms for Modbus/TCP
Electrical Lifetime	> 10 <sup>5</sup> h
Device Addressing	Programmable IP-Address and Network Parameters

\* Supply Voltage According to EN 50 178 (Safety Extra-Low Voltage)

##### Mechanical Data

Housing	Aluminum, Optional Stainless Steel			
Lifetime	Dependent on Shaft Version and Shaft Loading – Refer to Table			
Max. Shaft Load	Axial 40 N, Radial 110 N (9 lbs / 25 lbs)			
Moment of Inertia of Rotor	$\leq 30 \text{ gcm}^2$ (0.16 oz-in <sup>2</sup> )			
Friction Torque	$\leq 3 \text{ Ncm}$ (4.2 oz-in) (without Shaft Sealing)			
RPM (Continuous Operation)	max. 12,000 RPM			
Shock (EN 60068-2-27)	$\leq 30 \text{ g}$ (Half Sine, 11 ms)			
Permanent Shock (EN 60028-2-29)	$\leq 10 \text{ g}$ (Half Sine, 16 ms)			
Vibration (EN 60068-2-6)	$\leq 10 \text{ g}$ (10 Hz ... 1,000 Hz)			
Weight (Standard Version)	Single-Turn: ~500 g (~1.1 lbs)			
	Multi-Turn: ~700 g (~1.5 lbs)			
<b>Flange</b>	<b>Synchro (S)</b>		<b>Clamp (C)</b>	<b>Hub Shaft (B)</b>
Shaft Diameter	6 mm (~0.236 in)	10 mm (~0.394 in)	10 mm (~0.394 in)	15 mm (~0.591 in)
Shaft Length	10 mm (~0.394 in)	20mm (~0.787 in)	20 mm (~0.787 in)	*

\* Mating Shaft: min: 15 mm (~0.591 in) / max: 30 mm (~1.181 in)

### ABSOLUTE ROTARY ENCODER MODBUS/TCP

#### Minimum (Mechanical) Lifetime

Flange	Lifetime in 10 <sup>8</sup> Revolutions with F <sub>a</sub> / F <sub>r</sub>		
	40 N / 60 N 9 lbs / 13 lbs	40 N / 80 N 9 lbs / 18 lbs	40 N / 110 N 9 lbs / 25 lbs
C10 (Clamp Flange 10 x 20)	240	100	40
S10 (Synchro Flange 10 x 20)	210	90	30
S6 (Synchro Flange 6 x 10) without Shaft Sealing*	710	300	110

\* S6 (Synchro Flange 6 x 10) with Shaft Sealing: max. 20 N Axial, 80 N Radial (5 lbs / 18 lbs)

#### Environmental Conditions

Operating Temperature	0 .. +60 °C ( 32 ... 140 °F)*
Storage Temperature	- 40 ... + 85 °C ( - 40 ... + 185 °F)*
Humidity	98 % (No Condensation)
Protection Class (EN 60529)	Casing Side: IP 65
	Shaft Side: IP 64 (Optional with Shaft Sealing: IP66)

\* Cable Exit: - 30 ... + 70 °C ( - 22 ... + 158 °F) (Static), - 5 ... + 70 °C ( 23 ... 158 °F) (Flexing)

### ABSOLUTE ROTARY ENCODER MODBUS/TCP

#### Interface

##### Protocols

The communication is based on Modbus/TCP at data rates of 10 Mbps or 100 Mbps. TCP/IP stacks are available in all common operating systems. A data exchange in heterogeneous networks is possible by using the IP protocol. The control system send commands to and receive data from the Encoder by the exchange of commands in ASCII text. Java Applets providing a graphical user interface (GUI) and documentation is provided on a Web server integrated in the Encoder for convenient configuration and diagnosis. Based on

http, html and Java applets the GUI and all documents can be displayed on all common web browsers. In addition to the encoder parameters all necessary network parameters, like the IP-address, can be set. All parameters are saved in a non volatile memory so that the configuration is available promptly after a restart. Another feature of the web server is the optional output of messages via the SMTP protocol. In this way parameters and diagnosis messages can be sent by e-mail.

Modbus/TCP	The data will transports in the TCP-Frame. For detailed information's see the manual or on <a href="http://www.modbus.org">www.modbus.org</a> .
IP	A data exchange in heterogeneous networks is possible by using the well known internet protocol "IP". The universal IP addressing simplifies the implementation of communication processes significantly.
TCP	TCP-Protocol assures an error free data transmission.
HTTP	Via HTTP, a common web browser can be used for read out, configuration and diagnosis of the encoder with version A1.
SMTP	Via SMTP protocol messages of the encoder can simply be sent by e-mail with version A1.

### ABSOLUTE ROTARY ENCODER MODBUS/TCP

#### Programmable Parameters

The encoder is able to provide three different kinds of output data: the position value, a velocity value and a time stamp. These can be used in arbitrary combinations. The following parameters can be modified:

Parameter	Description
Used Scope of Physical Resolution (Parameter 1.)	Specifies the part of the physical resolution used for the encoder in physical steps. If e.g. for an encoder with a resolution of 8,192 steps per revolution 16,384 is chosen, the encoder will count 8,192 steps per revolution (if "Total scaled resolution" is set to the same value as "Used scope of physical resolution") and start with zero again after 2 revolutions. If this value is not set to a value which results in an integer division with the total physical resolution, the encoder value will jump to zero when passing the physical zero point.
Total Scaled Resolution (Parameter 2.)	Specifies the scaled resolution which is used over the area of physical steps defined by "Used scope of physical resolution". If e.g. the encoder is set as described above and "Total scaled resolution" is set to 10, the encoder will count 10 steps over the physical steps defined with "Used scope of physical resolution", i.e. 5 steps per revolution.
Code Sequence	The parameter Code Sequence (Complement) determines whether the output code increases or decreases when the axis is turned clockwise.
Preset Value	The preset value is the desired output value for the actual position of the axis. The actual output value will be set to this preset value.
Offset Value	This variable makes it possible to directly change the offset calculated and set by the preset function.

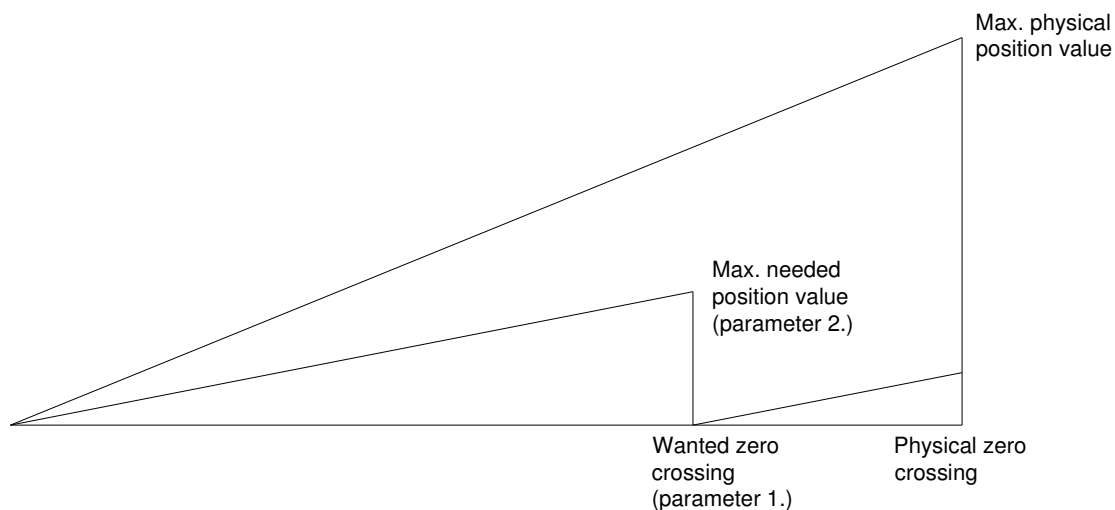

### ABSOLUTE ROTARY ENCODER MODBUS/TCP

The integrated web server of the encoder contains different web pages for information purposes and to parameterize the encoder. The html-page for configuration and diagnostics of the encoder provides the following website:

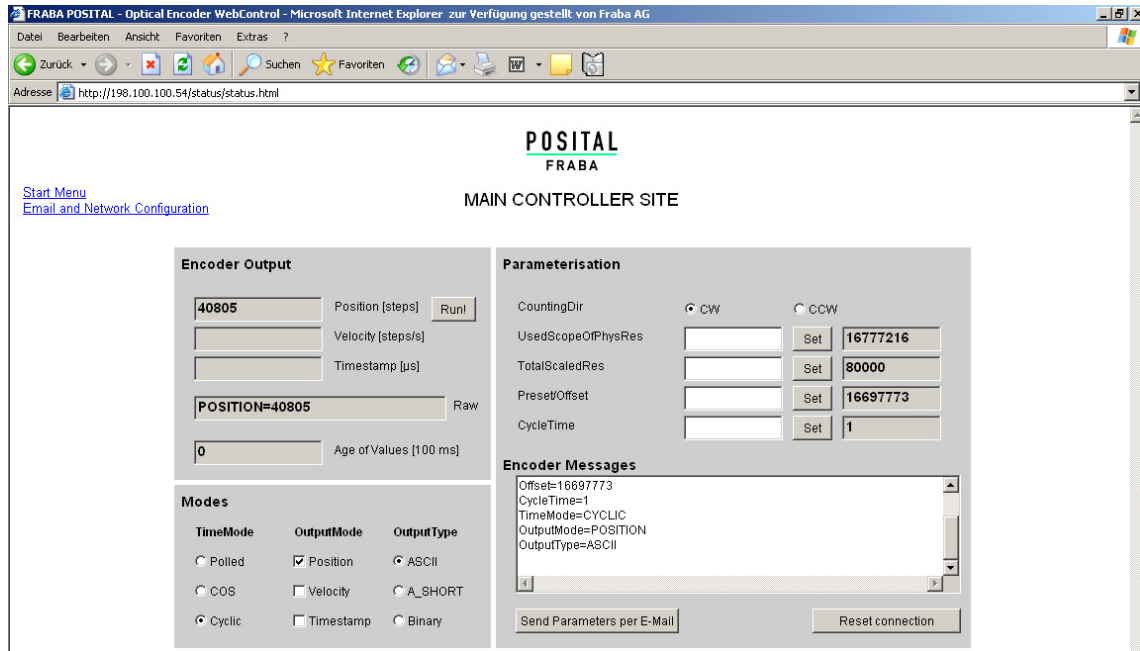

### Pinning

#### Connector Ethernet

4 pin female, D-coded

Pin Number	Signal
1	Tx +
2	Rx +
3	Tx -
4	Rx -

#### Connector Power Supply

5 pin male, A-coded

Pin Number	Signal
1	+24 V
2	+24 V
3	0 V
4	0 V
5	PE

Sketch on encoder view

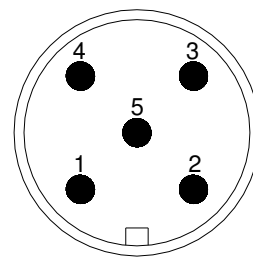
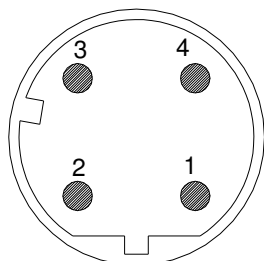

## ABSOLUTE ROTARY ENCODER MODBUS/TCP

### Mechanical Drawings (all dimensions in mm)

**Synchro Flange (S)**  
available in 2 versions

Synchro Flange	d / mm	l / mm
Version S06	6 <sub>f6</sub>	10
Version S10	10 <sub>h8</sub>	20

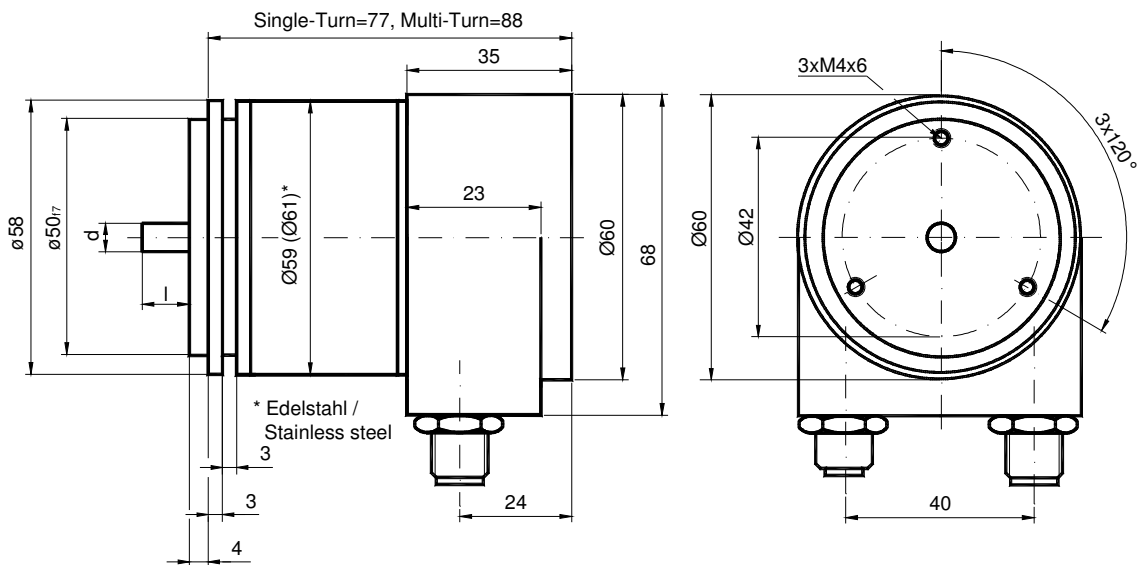

**Clamp Flange (C)**

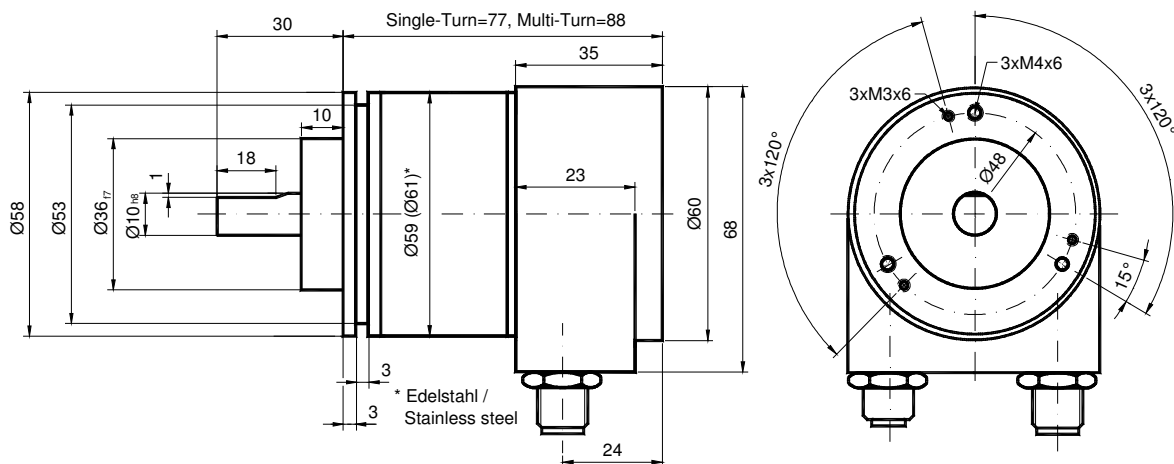

### ABSOLUTE ROTARY ENCODER MODBUS/TCP

#### Hub shaft (B)

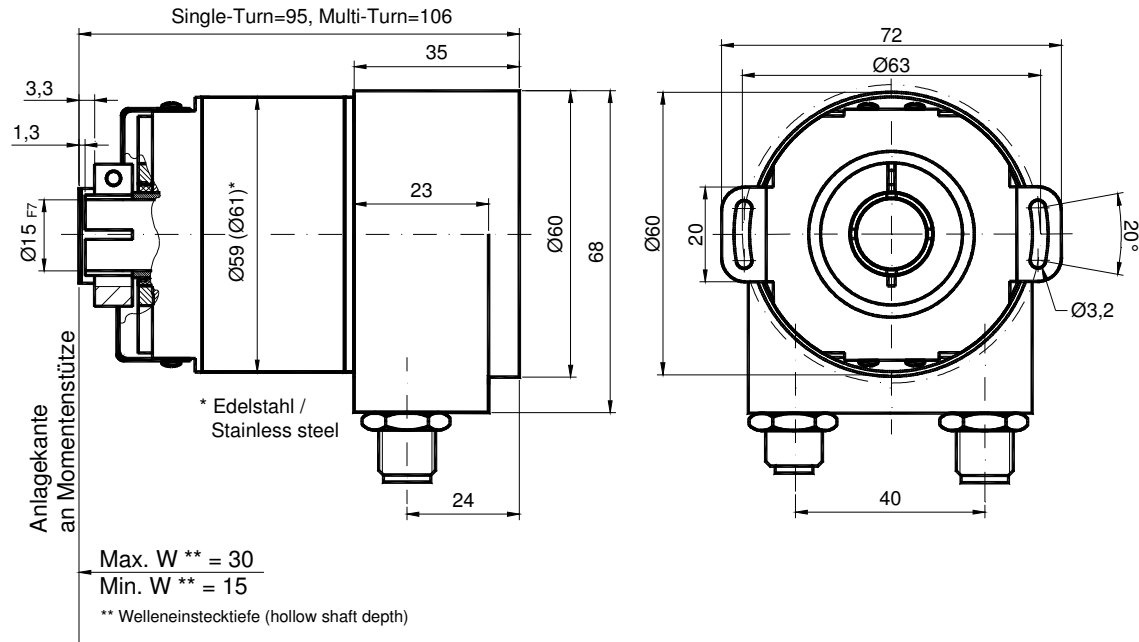

#### Mounting Instructions

The clamp ring should only be tightened after the shaft of the driving element was inserted into the hub shaft.

The diameter of the hub shaft can be reduced to 12 mm, 10 mm or 8 mm by using an adapter (this reducing adapter can be pushed into the hub shaft).

Maximum radial and axial misalignment of the drive shaft:

	Axial	Radial
Static	± 0.3 mm (~0.012 in)	± 0.5 mm (~0.020 in)
Dynamic	± 0.1 mm (~0.004 in)	± 0.2 mm (~0.008 in)



### ABSOLUTE ROTARY ENCODER MODBUS/TCP

#### Models/Ordering Description

Description	Type Key							
Optocode	<b>OCD-</b>	EM	00	B -	---	-	---	- PRM
Interface	Ethernet	<b>EM</b>						
	Modbus/TCP							
Version	2xM12		<b>00</b>					
Code	Binary			<b>B</b>				
Revolutions	Single-Turn						<b>00</b>	
(Bits)	Multi-Turn (4,096 Revolutions)						<b>12</b>	
	Multi-Turn (16,384 Revolutions)						14	
Steps per	8,192						<b>13</b>	
Revolution	65,536						16	
Flange / Shaft Diameter	Clamp Flange, Full Shaft:			Ø 10 mm			<b>C10</b>	
	Synchro Flange, Full Shaft:			Ø 6 mm			<b>S06</b>	
				Ø 10 mm			S10	
	Hub Shaft, Hub Shaft :			Ø 15 mm			<b>B15</b>	
Mechanical Options	Without						<b>0</b>	
	Shaft Sealing (IP66)						S	
	Customized						C	
Connection	M12 Connector						<b>PRM</b>	

**Standard = bold**, further models on request

All types UL-listed

### ABSOLUTE ROTARY ENCODER MODBUS/TCP

#### Accessories and Documentation

Description		Type
Male Cable Connector	M12, 4 Pin D-Coded	PAM4
Female Cable Connector	M12, 5 Pin A-Coded	PAM5
Coupling *	Diameter: Ø 10 mm	GS 10
	Diameter: Ø 6 mm	GS 06
Clamp Disc *	Set = 4 pcs. / OCD	SP 15
Clamp Half-Ring *	Set = 2 pcs. / OCD	SP H
Reducing Adapter **	15 mm to 14 mm (to ~0.551 in)	RR14
	15 mm to 12 mm (to ~0.472 in)	RR12
	15 mm to 11 mm (to ~0.433 in)	RR11
	15 mm to 12 mm (to ~0.472 in)	RR10
	15 mm to 12 mm (to ~0.472 in)	RR8
User Manual *	Installation / Configuration Manual, English	UMD-EM
	Installation / Configuration Manual, German	UME-EM

\* Note: All datasheets and manuals can be downloaded for free from our website [www.posital.com](http://www.posital.com)

\*\* usable only for full shaft

\*\*\* usable only for hub shaft, in stainless steel available too

We do not assume responsibility for technical inaccuracies or omissions. Specifications are subject to change without notice.