

## ABSOLUTE ROTARY ENCODER PROFIBUS-DP



### Main Features

- Compact and heavy-duty industrial model
- Certified: By Profibus Trade Org., CE
- Interface: Profibus-DP
- DPV2-Functionality
- Housing: 58 mm Ø
- Full or hollow shaft: 6 or 10 mm Ø / 15 mm Ø
- max. 65536 steps per revolution (16 Bit)
- max. 16384 revolutions (14 Bit)
- Code: Binary

### Programmable Parameters

- Direction of rotation (complement)
- Resolution per revolution
- Total resolution
- Preset value
- Output of velocity
- Time base for velocity
- Software Limit Switches
- Parameters for isochronous mode

### Mechanical Structure

- Flange and housing of Aluminum
- Shaft of stainless steel
- Precision ball bearings with sealing or cover rings
- Code disc made of unbreakable and durable plastic

### Electrical Features

- status indication with two LEDs in the connection cap
- 400 million write cycles
- Temperature insensitive IR-opto-receiver-ASIC with integrated signal conditioning
- Polarity inversion protection
- Over-voltage-peak protection

### ABSOLUTE ROTARY ENCODER PROFIBUS-DP

#### Technical Data

##### Electrical Data

Interface	Line-driver according to RS 485, galvanically isolated by opto-couplers
Transmission rate	max. 12 MBaud
Device addressing	Adjustable by rotary switches in connection cap
Supply voltage	10 – 30 V DC (absolute limits)*
Current consumption	max. 230 mA with 10 V DC, max. 100 mA with 24 V DC
Power consumption	max. 2.5 Watts
Step frequency LSB	800 kHz
Accuracy of division	$\pm \frac{1}{2}$ LSB (12 bit), $\pm 2$ LSB (16 bit)
EMC	Emitted interference: EN 61000-6-4
	Noise immunity: EN 61000-6-2
Electrical lifetime	$> 10^5$ h
MTTF <sub>d</sub>	146521 h / 118694 h (at 40°C, Single- / Multi-Turn, with Connection Cap)

\* Supply voltage according to EN 50 178 (safety extra-low voltage)

##### Mechanical Data

Housing	Aluminum, optional stainless steel
Lifetime	Dependent on shaft version and shaft loading – refer to table
Max. shaft loading	Axial 40 N, radial 110 N
Inertia of rotor	$\leq 30 \text{ gcm}^2$
Friction torque	$\leq 3 \text{ Ncm}$ (without shaft sealing)
RPM (continuous operation)	Max. 12,000 RPM
Shock (EN 60068-2-27)	$\leq 100 \text{ g}$ (halfsine, 6 ms)
Permanent shock (EN 60028-2-29)	$\leq 10 \text{ g}$ (halfsine, 16 ms)
Vibration (EN 60068-2-6)	$\leq 10 \text{ g}$ (10 Hz ... 2,000 Hz)
Weight (standard version)	Singleturn: $\approx 550 \text{ g}$
	Multiturn: $\approx 600 \text{ g}$
Weight (stainless steel version)	Singleturn: $\approx 1,100 \text{ g}$
	Multiturn: $\approx 1,200 \text{ g}$

Flange	Synchro (S)		Clamp (C)	Hollow shaft (B)
Shaft diameter	6 mm	10 mm	10 mm	15 mm
Shaft length	10 mm	20mm	20 mm	-
hollow shaft depth min. / max.	-	-	-	15 mm / 30 mm

### ABSOLUTE ROTARY ENCODER PROFIBUS-DP

#### Minimum (mechanical) lifetime

Flange	Lifetime in 10 <sup>8</sup> revolutions with F <sub>a</sub> / F <sub>r</sub>		
	40 N / 60 N	40 N / 80 N	40 N / 110 N
C10 (Clamp flange 10 x 20)	247	104	40
S10 (Synchro flange 10 x 20)	262	110	42
S6 (Synchro flange 6 x 10) without shaft sealing	822	347	133

S6 (Synchro flange 6 x 10) with shaft sealing: max. 20 N axial, 80 N radial

#### Environmental Conditions

Operating temperature	- 40 .. + 85°C
Storage temperature	- 40 .. + 85 °C
Humidity	98 % (without liquid state)
Protection class (EN 60529)	Casing side: IP 65 Shaft side: IP 64 (optional with shaft sealing: IP66)

#### Certification

Certificate	Comment
UL listed	File E251481
RoHS	According to EG-Guideline 2002/95/EG
Reach	Not affected
ISO 9001	

### ABSOLUTE ROTARY ENCODER PROFIBUS-DP

#### Interface

##### Installation

The rotary encoder is connected by two or three cables, depending on whether the power supply is integrated into the bus cable or connected separately. If the power supply is integrated into the bus cable one of the cable glands can be fitted with a plug. The cable glands are suitable for cable diameters from 6.5 up to 9 mm.

Termination resistor is integrated in the connection cap. It must be switched on if the encoder is connected at the end or the beginning of the bus.

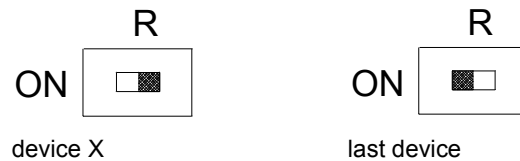

Termination Resistor

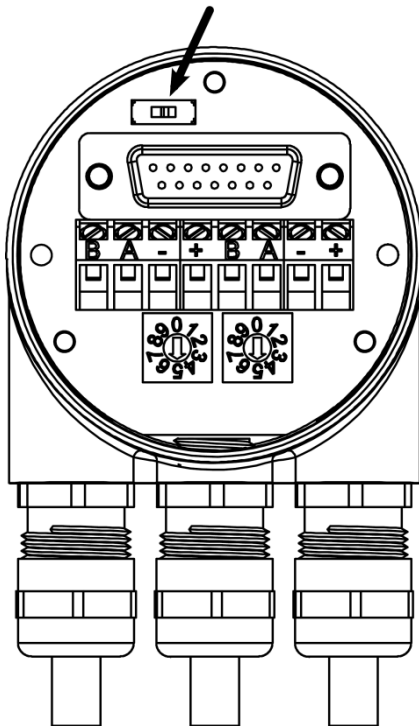

The Profibus-DP device address is set by user-friendly rotary switches in the connection cap. Allowed addresses are between 1 and 99, each can only be used once. The connection cap can easily be opened for installation by removing the two cap screws.

Connecting the data line and the power supply

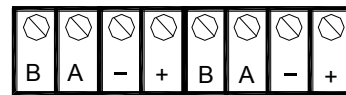

Clamp	Description
B (left)	Bus line B (Bus in)
A (left)	Bus line A (Bus in)
-	0 V
+	10 – 30 V
B (right)	Bus line B (Bus out)
A (right)	Bus line A (Bus out)
-	0 V
+	10 – 30 V

The power supply has to be connected once (no matter which clamps). If the terminating resistor is switched on the outgoing bus lines are disconnected.

A GSD-file is necessary for installing the encoder. The GSD-file and the detailed user manual can be downloaded from our homepage ([www.posita.de](http://www.posita.de)).

The connection cap is provided with two LEDs on the backside, which optically represent the device status. This can be very useful for installing and setting-up the encoder.

### ABSOLUTE ROTARY ENCODER PROFIBUS-DP

#### Interface

##### Programmable Parameters

The Profibus-DP interface supports CLASS 1 and CLASS 2 functionality according to the encoder profile\*. In addition to these functions the GSD-file supports further features, for example software

limit switches. Further more, the following encoder parameters can be programmed directly via the Profibus-DP network without any extra device:

Parameter	Comment
Counting Direction	This parameter counting direction defines whether the output code increases or decreases when the shaft rotates clockwise.
Resolution per Revolution	The parameter 'resolution per revolution' is used to program the desired number of steps per revolution. Each value between 1 and the physical resolution per revolution can be programmed.
Total Resolution	This parameter is used to program the desired number of measuring units over the total measuring range. This value may not exceed the total physical resolution of the absolute rotary encoder.
Preset Value	The preset value is the desired position value, which should be reached at a certain physical position of the axis. The position value is set to the desired process value by the parameter preset.
Velocity	The implemented software can additionally deliver the current velocity. This value is transmitted in binary code, 16 Bit, in addition to the process value. It is possible to choose between four different units: steps per 10 ms, per 100 ms, per 1000 ms and revolutions per minute.
Software limit switches function	Two software limit switches can be set. If the position value falls below the lower or exceeds the higher limit switch, a status bit in the process value is set.
Teach-in (Online parameterization)	A special mode is available for commissioning phase of the device. This makes it possible to change parameters while the encoder is in data exchange mode. For continuous operation another mode is available in which the parameters are protected against unintentional changes.

\* The Profibus-DP profile for encoder can be ordered from  
Profibus Nutzerorganisation e.V.  
Haid und Neu-Str. 7,  
D-76131 Karlsruhe, Germany  
with order-No. 3.062.

### ABSOLUTE ROTARY ENCODER PROFIBUS-DP

#### Mechanical Drawings

##### Synchro flange (S)

Available in 2 versions

Synchro flange	d / mm	l / mm
Version S06	6 <sub>f6</sub>	10
Version S10	10 <sub>h8</sub>	20

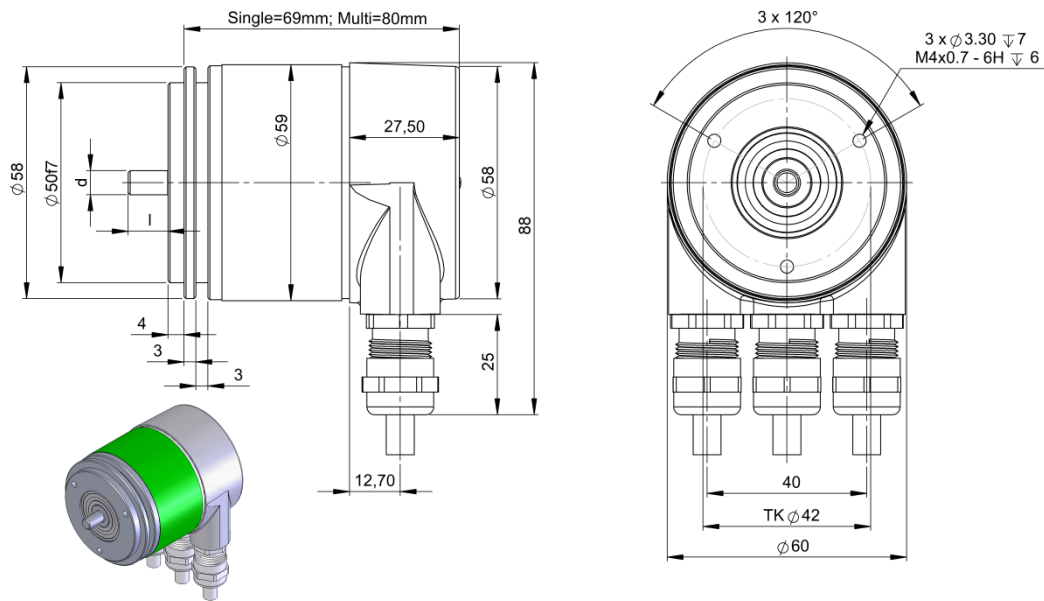

##### Clamp flange (C)

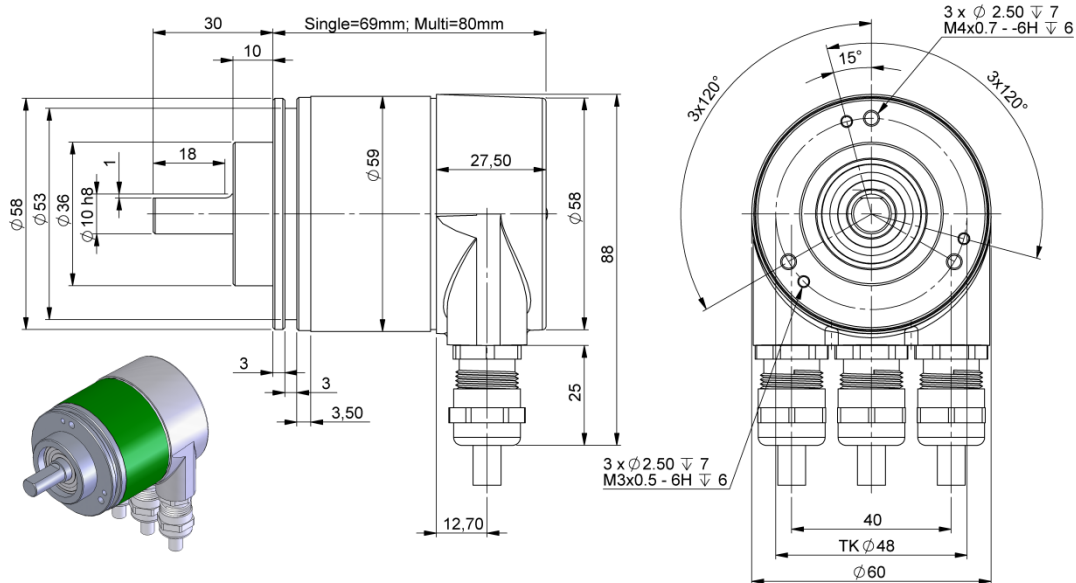

## ABSOLUTE ROTARY ENCODER PROFIBUS-DP

### Hollow shaft (B)

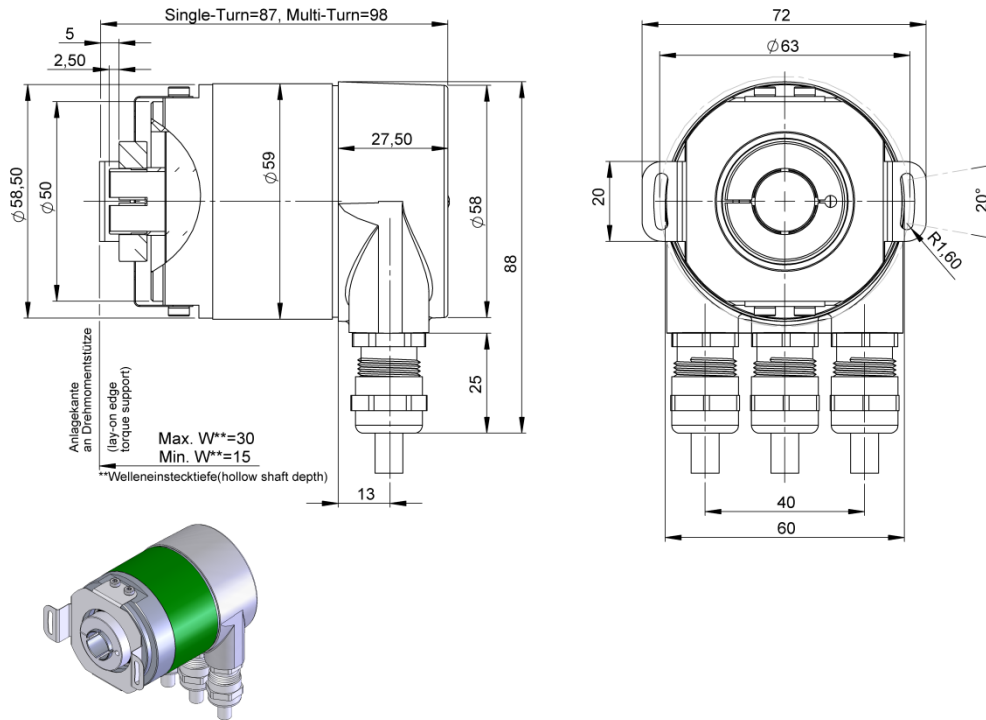

### Mounting instructions

The clamp ring may only be tightened if the shaft of the driving element is in the hollow shaft.

The diameter of the hollow shaft can be reduced to 12mm, 10 mm or 8 mm by using an adapter (this reducing adapter can be pushed into the hollow shaft).

Allowed shaft movements of the drive element are listed in the table.

	axial	radial
static	± 0.3 mm	± 0.5 mm
dynamic	± 0.1 mm	± 0.2 mm

### ABSOLUTE ROTARY ENCODER PROFIBUS-DP

#### Versions / Ordering description

Description	Type Key							
Optocode	<b>OCD-</b>	DP	C1	B -	---	---	---	0CC
Interface	Profibus	<b>DP</b>						
Version			<b>C1</b>					
Code	Binary			<b>B</b>				
Revolutions (Bits)	Singleturn				<b>00</b>			
	Multiturn (4096 revolutions)				<b>12</b>			
	Multiturn (16384 revolutions)				<b>14</b>			
Steps per revolution (Bits)	4096 (0.09°)					12		
	8192 (0.04°)					<b>13</b>		
	65536 (0.005°)					16		
Flange / Shaft Diameter	Clamp Flange, Full Shaft, Ø 10 mm						<b>C10</b>	
	Synchro Flange, Full Shaft, Ø 6 mm						<b>S06</b>	
	Synchro Flange, Full Shaft, Ø 10 mm						S10	
	Blind Hollow Shaft, Ø 15 mm						<b>B15</b>	
Mechanical options	Without							<b>0</b>
	Shaft sealing (IP66)							S
	Stainless steel version *							V
	Customized							C
Connection	With connection cap AH58-B1DP-3PG							<b>H3P</b>
	With connection cap AH58-B1DP-2M20							H2M
	Without connection cap **							HCC

**Standard = bold**, further models on request

\* Delivery time: on request

\*\* For the function of the encoder a connection cap is needed. To order this encoder type only makes sense for spare part / replacement usage



### ABSOLUTE ROTARY ENCODER PROFIBUS-DP

#### Accessories and Documentation

Description	Article name	Article number
Aluminium housing with three M12 cable glands for cable diameters between 6,5 – 9 mm	AH 58-B1DP-3PG	0246370340
Stainless steel housing with three M12 cable glands for cable diameters between 6,5 – 9 mm	AH 58-B1DP-3PG-VA	0246370355
Aluminium housing with two M20 cable glands for cable diameter between 9 – 13 mm	AH 58-B1DP-2M20	0246370344
Shaft coupling ** Drilling: 10 mm / 10 mm Drilling: 6 mm / 6 mm	GS 10	29100450
	GS 06	29100350
Spannscheiben ** 4 Stück / Drehgeber	SP 15	32400155
Spannhälbringe **2 Stück / Drehgeber	SP H	32400152
Reduziererring *** 15 mm auf 12 mm 15 mm auf 10 mm 15 mm auf 8 mm	RR12	32220291
	RR10	32220292
	RR8	32220295
GSD-Datei * Wird bei Neueinsatz einmalig benötigt	-	-
Installation / configuration manual for Profibus *	German	UMD-B1DP
	Englisch	UME-B1DP

\* These can be downloaded free of charge from our homepage [www.posital.eu](http://www.posital.eu)

\*\* Not for hollow shaft

\*\*\* Only for hollow shaft

We do not assume responsibility for technical inaccuracies or omissions. Specifications are subject to change without notice.