

**Flow Rate Sensor QS-2-B-008-3/8"**

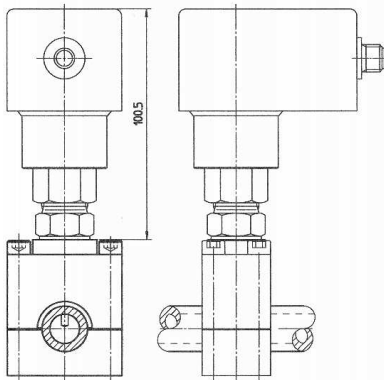

Der Strömungssensor muß mit der runden Gehäuseseite entgegen der Strömungsrichtung montiert werden.

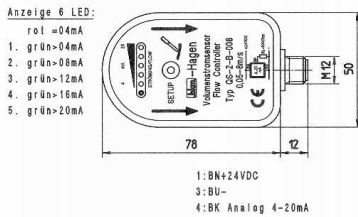
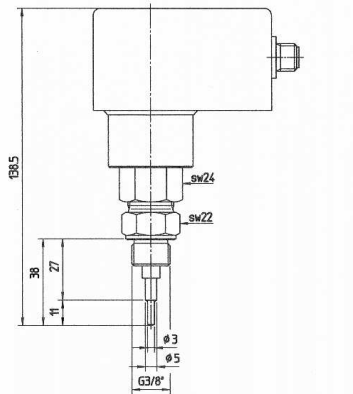
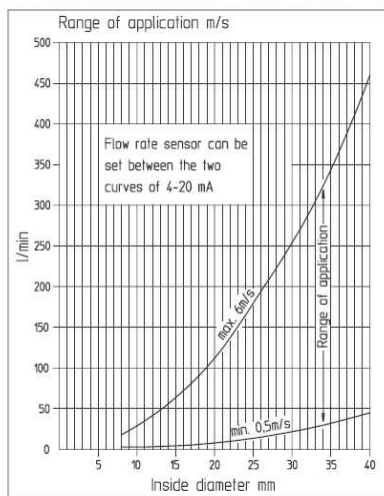

- Measuring range 0.05... 8 m/s (Hydraulic Oil)
- Range of application 0,50...6 m/s
- Output 4 ... 20 mA / 3 wires
- Protection mode IP 65
- M12 universal connector system
- Housing made of PBT
- Sensor head made of stainless steel
- Range setting by micro-switches
- For pipe diameters Ø 12 mm and larger

**Description**

The flow rate sensor QS-2-B-008 was developed for monitoring hydraulic systems and allows the connection of **fluid-Check®**, the diagnostic system for hydraulic plants. The flow rate sensor provides an indirect measurement system that is based on the calorimetric principle, which provides a direct measurement of the flow velocity in l/min rather than measuring the volume flow. Typical fields of application include systems and plant engineering, automation, air conditioning, and refrigeration. In addition to its inexpensive, robust and compact design, it stands out by its extensive measurement range.

As a standard, the sensor head is made of stainless steel 1.4571.

**Installation with serv-Clip 2**

The patented measuring connector **sc-2-...** was developed for installation on pressureless hydraulic pipes.

After installation, the measuring connection can continuously be used, supporting operating pressures of up to 630 bar.

The measuring connection **sc-2-...** comes pre-mounted, including measurement coupling and needle, and is mounted as described in the corresponding installation instructions.

**To install the flow rate sensor, the created 2 mm hole must be widened.**

**In the first step, the short needle of the measurement coupling is screwed down completely - without applying much force - until the stop is reached. Then it is unscrewed again. In the second step, the long needle is screwed down completely and unscrewed again, too.**

Now the flow rate sensor can be screwed into the **serv-Clip®**. The measuring connection is completely tight and is ready for continuous use.

Using the **serv-Clip® sc-2-...**, the flow rate sensor can be installed easily, quickly and safely even by non-technical staff. The whole process takes a few minutes only. No special tools are required for the installation of the **serv-Clip®** and the **flow rate sensor**.

The system is completely tight, preventing any contamination of the hydraulic oil and ensuring sustained operational safety. The measuring connections are continuously available for measurement applications.

**Specifications**

Measuring range	0.05... 8 m/s (Hydraulic Oil)
Range of application	0,50...6 m/s
Temperature range	-30 ... +120 °C
Accuracy	+/- 2 K
Repeatability	Better than 1 K
Pressure range	Up to P <sub>B</sub> 630 bar
Output signal	4 ... 20 mA
Power supply	15 ... 30 V DC, protected against reverse connection
Configuration	2 wires
Protection mode	IP 65
Linearity	0.2 % typ. / max. 0,5 %
Threaded coupling	G3/8" male
Electrical connection	Right-angle plug connection Type DIN 43650 A